

DOVETAIL P.D.Q. PROGRAM REQUIREMENTS

HARTLAND
CUTTING TOOLS INC.

DOVETAIL SPEC. SHEET

CUSTOMER TOOL #

DATE:

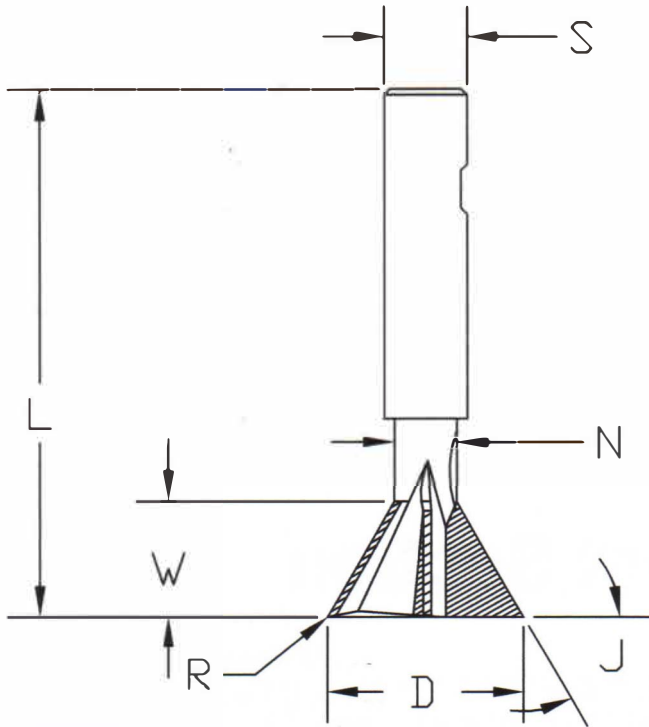

D= _____ DOVETAIL DIAMETER
 N= _____ NECK DIAMETER
 W= _____ WIDTH OF DOVETAIL
 J= _____ DOVETAIL ANGLE
 M= _____ MATERIAL TO BE CUT
 S= _____ SHANK SIZE
 R= _____ RADIUS (IF NEEDED)
 L= _____ OVERALL LENGTH

FLAT YES or NO

END CUTTING DOWN TO DIA.

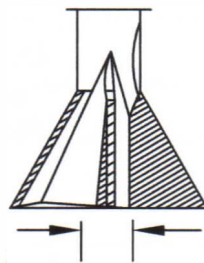

_____ MIN. CUT

"D" Tolerance (± 0.003) Inches
 "S" Tolerance ($+0.000/-0.005$)
 "W" Tolerance (± 0.010)
 "L" Tolerance (± 0.06)
 "N" Tolerance (± 0.015)

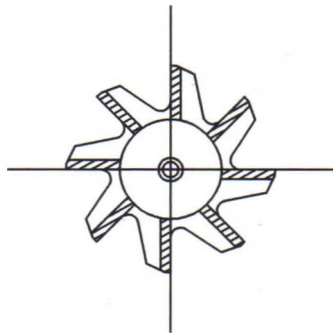

* UNLESS OTHERWISE SPECIFIED
 TEETH/FLUTE GEOMETRY
 IS UP TO HARTLAND

MATERIAL OF TOOL	4140 BODY			
	C-2MG TIPS			
* TEETH DESIRED	6	8	10	12 Other
COATING NEEDED	TIN		DIC	
	TICN		ZrCN	
	TIALN		ALTIN	
OTHER COATING			Varlantic	
COOLANT FED INTO FLUTES	YES		NO	
QUANTITIES FOR QUOTING				
Special Notes				

REQUIREMENTS FOR P.D.Q. (2 Week) DELIVERY

* Quantities less than 12 pcs. (Or else, partial is shipped against order)
 * Non Coated Tools * Add One Week for
 Coating * Minimum Order Quantity of (2) Pieces

800-535-HART TOLL-FREE
 847-639-7555 FACSIMILE
www.hartlandtool.com