

(2-2) SUBLAND P.D.Q. PROGRAM REQUIREMENTS

HARTLAND
CUTTING TOOLS INC.

SUBLAND DRILL SPEC. SHEET

CUSTOMER TOOL #

DATE:

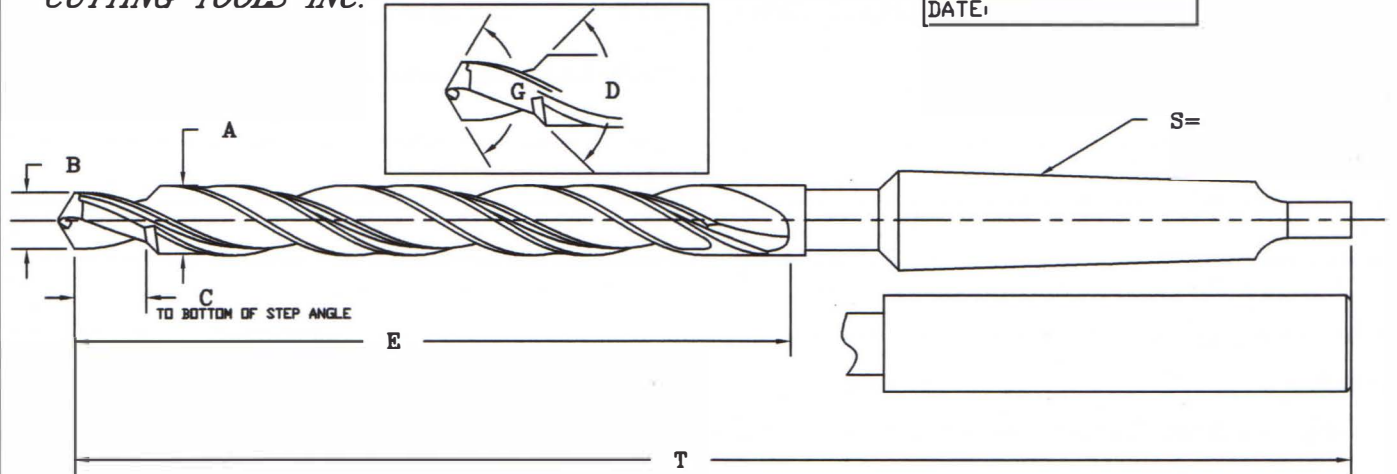

A= _____ LARGE DIAMETER
 B= _____ SMALL DIAMETER
 C= _____ STEP LENGTH
 D= _____ STEP ANGLE (INCL.)
 M= _____ MATERIAL TO BE CUT
 S= _____ SHANK SIZE

E= _____ FLUTE LENGTH
 L= _____ TANG LENGTH
 W= _____ TANG THICKNESS
 G= _____ POINT ANGLE
 T= _____ OVERALL LENGTH
 N= _____ HOLE STYLE #

"A" Tolerance (+.0000/-0.0005) Inches
 "A" Tolerance (+0.0000/-0.013) Metric
 "B" Tolerance (+.001/-0.001) Inches
 "B" Tolerance (+0.025/-0.025) Metric
 "A" & "B" Backtaper (.0002/inch) Inches

Standard Point Style is a 118° "U" NOTCH Unless Stated Otherwise

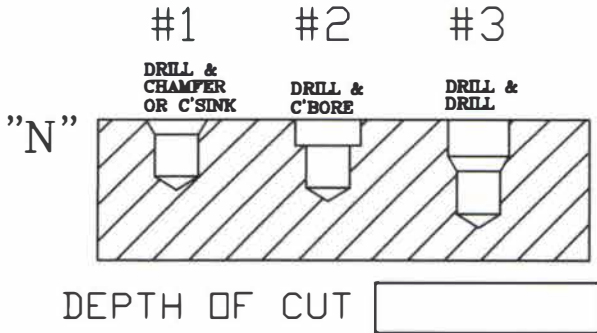

MATERIAL OF TOOL	H.S.S.	M-7 IS STD. GRADE
	COBALT	M-42 IS STANDARD
COATING NEEDED	TIN	DIC
	TICN	ZrCN
	TIALN	AL-TIN
OTHER COATING		Variantic
COOLANT FED THRU FLUTES	YES	NO
QUANTITIES FOR QUOTING	<input type="text"/>	
Special Notes	<input type="text"/>	

REQUIREMENTS FOR P.D.Q. (3 Week) DELIVERY

* Quantities less than 48 pcs. * Bright Finish * Overall Lengths less than 6'
 * Standard Grade of Steel available * Standard H.S.S. Grades of M-7 or M-2
 * Standard Cobalt Grade of M-42 or M-35 * Carbide Tipped Sublans will take longer
 * Diameter less than 1.50" * Minimum Order Quantity of (3) Pieces

800-535-HART TOLL-FREE
 847-639-7555 FACSIMILE
 www.hartlandtool.com