

# HARTLAND CUTTING TOOLS INC.

240 Jandus Road, P.O. Box 517  
Cary, Illinois 60013  
847/639-9400 Facsimile # 847/639-7555

## TWO FLUTE DRILLS

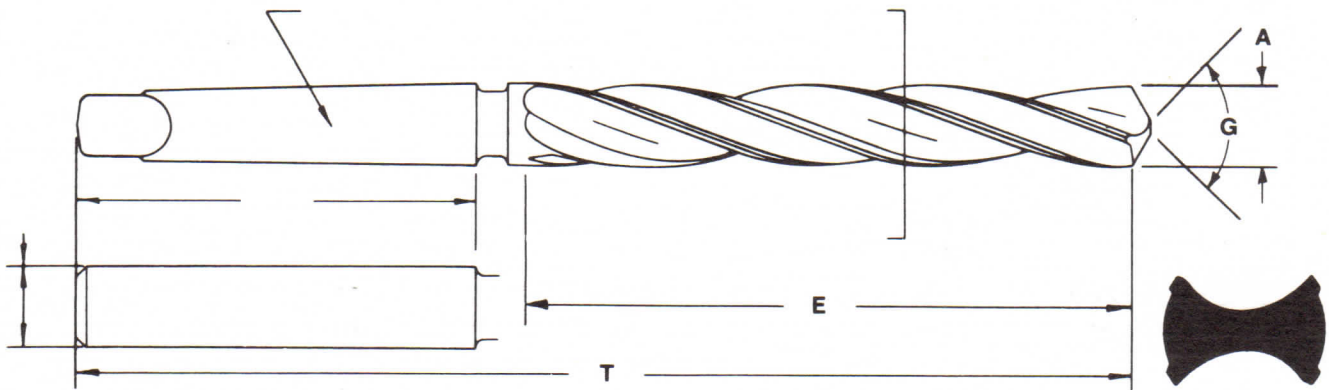

### REQUIRED SPECIFICATIONS

- A= \_\_\_\_\_ Drill Diameter  
M= \_\_\_\_\_ Material to be Cut  
N= \_\_\_\_\_ Depth of Cut  
(Thru or Partial)  
O= \_\_\_\_\_ Bushing Used  
(Yes/No)  
E= \_\_\_\_\_ Flute Length  
F= \_\_\_\_\_ Spiral  
G= \_\_\_\_\_ Point Angle  
H= \_\_\_\_\_ Web Style  
J= \_\_\_\_\_ Margin Style  
Slow Spiral  
Standard Spiral  
Fast Spiral  
Heavy Duty Web  
Standard Web  
T= \_\_\_\_\_ Overall Length  
\_\_\_\_\_ Surface Finish

ORDER  P.O. # \_\_\_\_\_

QUOTE  INQUIRY # \_\_\_\_\_

QUANTITIES \_\_\_\_\_

DISTRIBUTOR \_\_\_\_\_

CUSTOMER \_\_\_\_\_